



Model 42-160

SINGLE STAGE PROGRAMMABLE THERMOSTAT

1 Heat / 1 Cool Single Stage Thermostat.

5+2 Programmable, Compatible with Gas Heat & Heat Pump System

Installation and Operation Manual

SPECIFICATIONS:-----

Power Supply: 20VAC - 30VAC 50-60HZ or 2 x AA Battery powered.

Terminal Load: 1.0A per terminal, 3.0A maximum total load

Set Point Temperature Range: 7°C to 32°C

Accuracy: +/- 0.5°C.

Dimensions: 152mm W X 120mm H X 28mm D

Color: White

FEATURES:-----

- Large LCD display with backlight, continuous backlight option.
- Simultaneous heat and cool set point storage.
- Display of room temperature, set temperature and current time simultaneously.
- Fan switch with ON and AUTO.
- Permanent user setting retention during power loss. No batteries are required.
- Operates from 24VAC, or from 2 size "AA" alkaline batteries.
- Optional temperature display of Fahrenheit or Celsius.
- Filter Clean / Change Indicator.
- Low Battery Indicator.
- Display temperature calibration.
- Separate 5-day (weekday) and 2-day (Saturday/Sunday) programming with four separate time/temperature periods per day.
- Intelligent Recovery Option for optimizing comfort.

IMPORTANT SAFETY INFORMATION-----

- Always turn off power at the main power source by removing the fuse, or switching the circuit breaker to the off position before installing, removing, cleaning, or servicing this thermostat.
- Read all of the information in this manual before installing this thermostat.
- Use a professional contractor to install this thermostat.
- This is a 24VAC low-voltage thermostat. **DO NOT INSTALL ON VOLTAGES HIGHER THAN 30 VAC.**
AN OPTIONAL SMARTPAK INTERFACE MODULE IS AVAILABLE FOR HIGH VOLTAGE SWITCHING
- ALL wiring must conform to local and national building and electrical codes.
- Do not short (jumper) across terminals on the gas valve or at the system control to test installation. This will damage the thermostat and void the warranty.
- Do not switch the system to cool if the temperature is below 10°C. This can damage the air conditioning system and may cause personal injury.

- Replace batteries when the battery icon indicates the low battery (2 AA Alkaline Batteries)
- Change or clean your Return Air Filter (if installed) when the Filter Change Icon begins blinking.

REMOVING THE OLD THERMOSTAT-----

WARNING!: Electrical Shock Hazard

1. Turn off power at the main service panel by removing the fuse or switching the appropriate circuit breaker to the OFF position before removing the existing thermostat.
2. Turn off power to the heating and cooling system by removing the fuse or switching the appropriate circuit breaker off.
3. Remove the cover of the old thermostat. This should expose the wires.
4. Label the existing wires from the existing thermostat before removing.
5. After labeling the wires, remove the wires from the wire terminals.
6. Remove the existing thermostat from the wall.
7. Refer to the following section for instructions on how to install this thermostat.

INSTALLING YOUR THERMOSTAT-----

ATTACH THERMOSTAT BASE TO WALL PULL THE COVER OFF THE BASE.

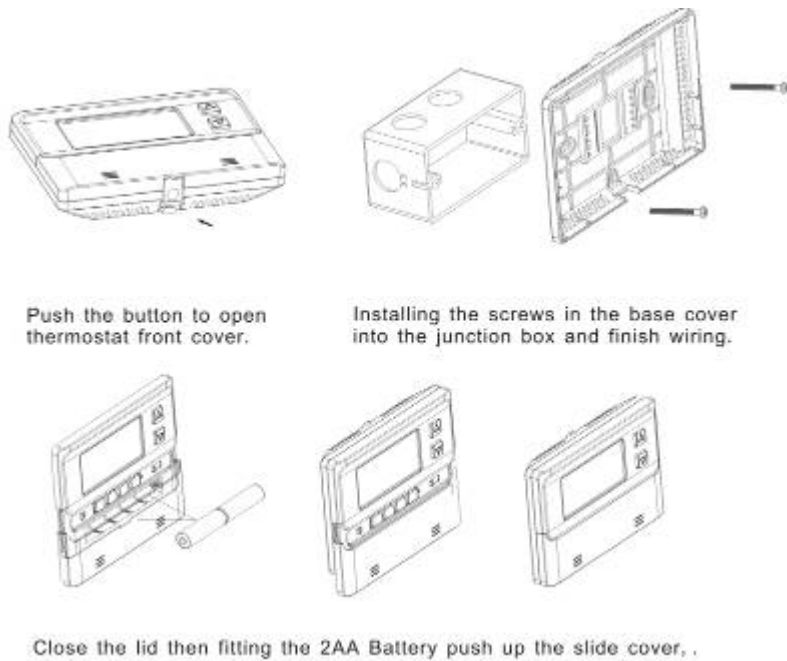

Figure 1

WARNING!: Electrical Shock Hazard

Turn off power at the main service panel by removing the fuse or switching the appropriate circuit breaker to the OFF position before removing the existing thermostat.

1. Turn off power to the heating and cooling system by removing the fuse or switching the appropriate circuit breaker off.
2. Place the system switch (**COOL/OFF/HEAT**) in the **OFF** position.
3. Place the **FAN (AUTO/ON)** switch in the **AUTO** position.
4. Gently pull the cover straight off the base. (See figure 1.)

5. Put the thermostat base against the wall where you plan to mount it. (Be sure the wires will feed through the wire opening in the base of the thermostat.)
6. Mark the placement of the mounting holes.
7. Move the base out of the way. Drill mounting holes. Use a hammer to tap in the supplied anchors into the mounting holes.
8. Fasten the base loosely to the wall as shown in Figure 1, using two mounting screws. Place a level against the bottom of the base and adjust until level, then tighten the screws. (Leveling is for appearance only, and will not affect thermostat operation.)
9. Insert stripped, labeled wires into matching wire terminals. See "Wiring Diagrams"

CAUTION: Be sure exposed portions of wires do not touch other wires.

10. Tighten screws on terminal block. Gently tug on each wire to be sure of proper connection. Double check that each wire is connected to the proper terminal.

CAUTION: Installing batteries backwards will damage the thermostat.

11. Install two fresh "AA" alkaline batteries in the battery compartment. Be sure to match positive (+) ends of batteries with positive (+) battery terminals in the battery compartment. (The thermostat will operate from 2 size "AA" alkaline batteries or 24VAC power. When operated from 24VAC power, your thermostat will maintain time and continuously display the temperature during a loss of AC power with the batteries installed.)
12. Replace the cover on the thermostat by snapping it in place.
13. Turn on power to the system at the main service panel.
14. Test thermostat operation as described in the following section.

Wiring Diagrams

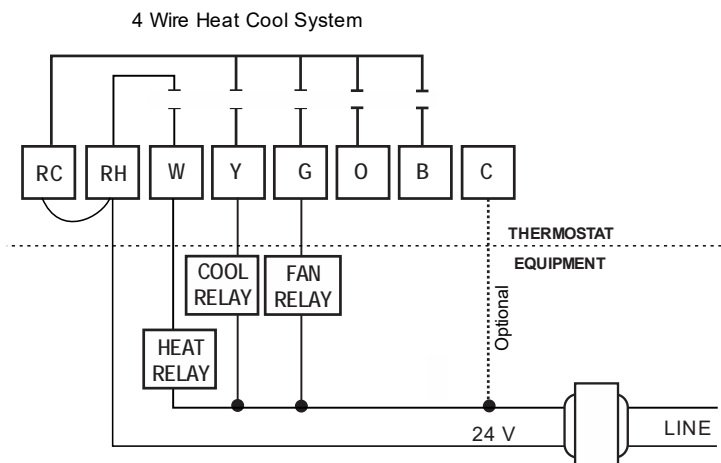
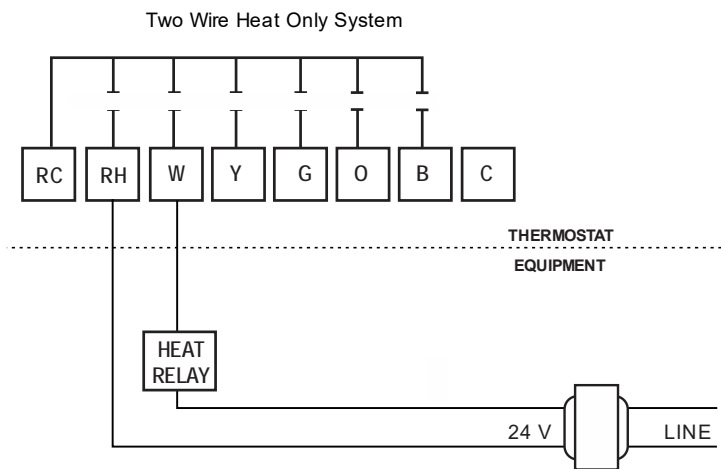

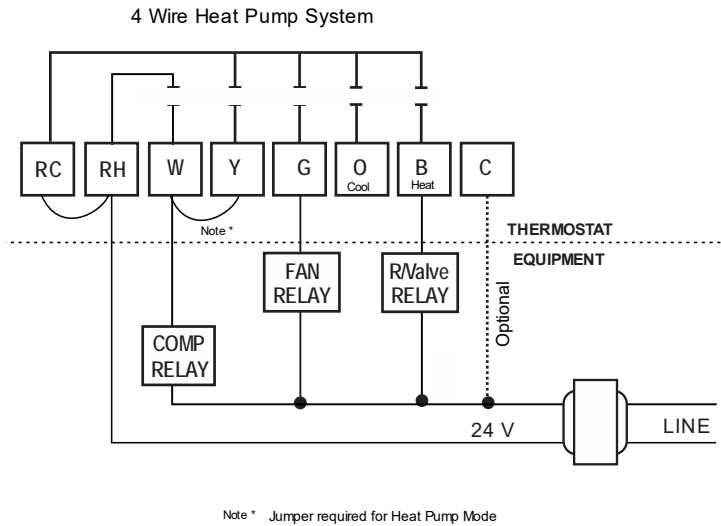

THERMOSTAT LCD DISPLAY

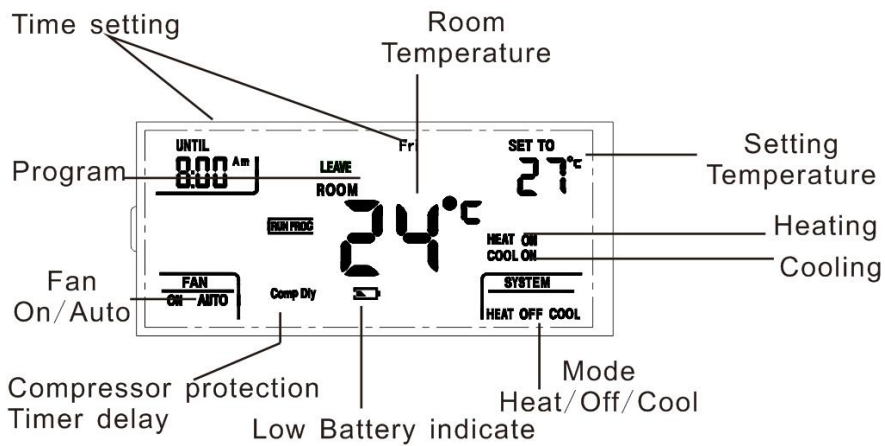
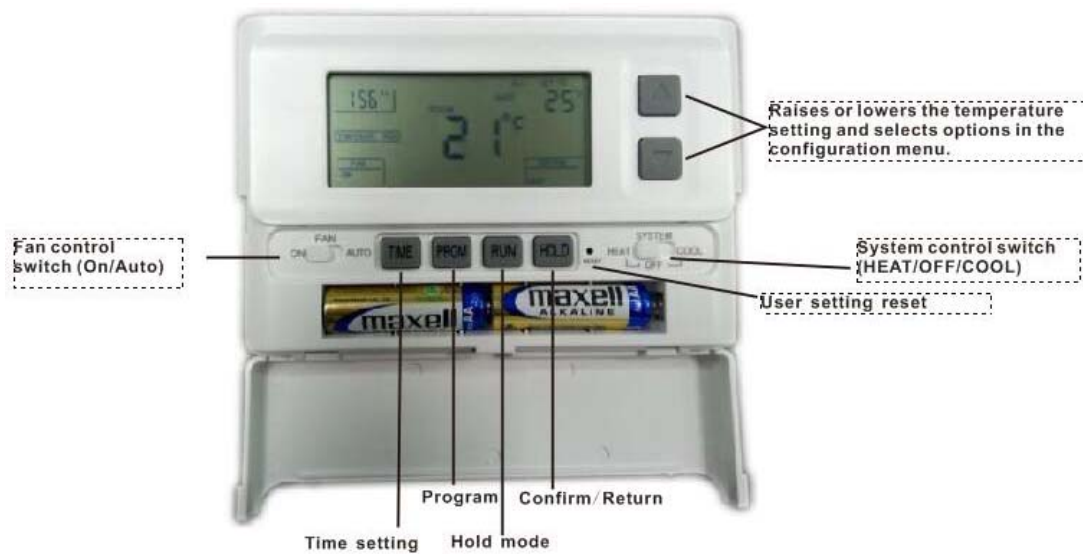

Figure 2

THERMOSTAT BUTTONS AND SWITCHES



CHECK THERMOSTAT OPERATION-----

If at any time during testing your system does not operate properly, contact a qualified service person.

Turn on power to the system.

Heating System

1. Move the **SYSTEM** switch to the **HEAT** position. If the auxiliary heating system has a standing pilot, be sure to light it.
2. When the (FA)st heating cycle rate is selected in the configuration menu, (see configuration menu item 2), the thermostat will call for heat at 0.5°C below set-point, and turn off at set point. When the (SL)ow heating cycle rate is selected, the thermostat will call for heat at 1.5°C below set-point, and turn off at set-point. When the thermostat calls for heat, the display will show **Heat On**. If the **Heat On** display is flashing, the compressor lockout feature is operating in the heat pump mode. (Note: See Configuration menu item 8).

Cooling System

CAUTION! To prevent compressor and/or property damage, if the outdoor temperature is below 10°C, **DO NOT** operate the cooling system.

1. Move the **SYSTEM** switch to the **COOL** position.
2. When the (FA)st cooling cycle rate is selected in the configuration menu, (see configuration menu item 2), the thermostat will call for cooling at 0.5°C above set-point, and turn off set point. When the (SL)ow cool cycle rate is selected, the thermostat will call for cooling at 1.5°C above set-point, and turn off at set-point. When the thermostat calls for cooling, the display will show **COOL On**. If the **COOL On** display is flashing, the compressor lockout feature is enabled. (Note: See Configuration menu item 8).

If all functions operate properly, the thermostat is installed correctly.

FAN OPTION SWITCH

Fan Operation

Move the system switch to the **OFF** position. If your system does not have a "G" (Fan) terminal connection, skip to the Heating System.

1. Move the fan switch to the **ON** position. The blower should begin to operate.
2. Move the fan switch to the **AUTO** position. The blower should stop immediately.

This thermostat is configured from the factory to energize the fan on a call for heat. If your system is an electric heat or heat pump that **REQUIRES** the thermostat to turn on the fan on a call for heat, place the fan option switch in the **ELEC** position. If your system does not require the thermostat to energize the fan on a call for heat such as fossil fuel (gas, oil, etc.), forced air system as well as hydraulic heating systems, place the fan option switch in the **GAS** position.

BATTERY OPERATION

The thermostat will operate from 2 size "AA" alkaline batteries or 24VAC power. When operated from batteries, connection to the "C" (common) or (neutral) terminal is not required.

NOTE: When operated from batteries (No "C" terminal connection), the LCD display backlight options are limited to option 1 (disabled) or option 2 (30 second illumination after each button press).

Replacing Batteries

If your thermostat was pre-installed, the batteries may be in place. If the battery icon on the display is flashing, it indicates that the batteries need to be replaced. When the thermostat is powered only by battery, the battery icon will flash for approximately 2 months before the batteries are expected to expire. Then the thermostat will cut power to the heating/cooling system.

Important: Replace the batteries when the low battery message flashes on the display. This will keep the thermostat operating properly. With two "AA" batteries installed, your thermostat will maintain time and continuously display the temperature during a loss of AC power.

1. Place the COOL/OFF/HEAT switch in the OFF position.
2. Put the FAN AUTO/ON switch in the AUTO position.
3. Gently open the front cover
4. Install two "AA" alkaline batteries in the battery compartment. Be sure to match the positive (+) ends of the batteries with the positive terminals marked in the battery compartment.

THERMOSTAT OPERATION

1. Setting the thermostat

This thermostat is very easy to operate. Set the SYSTEM switch to either HEAT or COOL, then press the ▲ or ▼ buttons until the temperature you want to maintain is shown on the right side of the display. If you want to turn the system off, just move the SYSTEM switch to the OFF position and the FAN switch to the AUTO position.

2. Set current day and time

Press the TIME button. The hours display will begin to blink.

Press the ▲ or ▼ buttons until you reach the correct hour and AM/PM designation. (AM begins at mid-night, and PM begins at noon).

Press the TIME button again. The minutes display will begin to blink.

Press the ▲ or ▼ buttons until you reach the correct minutes.

Press the TIME button again. The day of the week will begin to blink.

Press the ▲ or ▼ buttons until you reach the correct day of the week.

Press the TIME button again. The display will now indicate the correct time and day of the week.

3. Filter timer

a) When in configuration the selections are in months, each month selections are equal to 30 days.

b) Move the SYSTEM switch to the HEAT or COOL position, then press and hold the ▲ and ▼ buttons for 5 seconds to review filter running days.

To exit the review menu press the ▲ or ▼ buttons one time. Or If no buttons are pressed within 15 seconds, the thermostat will exit the configuration menu. In review mode, press and hold the ▲ and ▼ 15 sec. to clean the filter warning. It will show "dEF" blink. To reset the filter days – refer to configuration item 5 operation.

5	PRGM	FL (00)	00, 1 thru12	Select filter time in months. Default = 00. A selection of "00" deactivates the filter feature.
---	------	---------	--------------	---

MANUAL OPERATION

1) Hold Temperature

With the SYSTEM switch set to HEAT or COOL, momentarily press the HOLD button. HOLD will be displayed. Use the ▲ or ▼ buttons to adjust the temperature. The thermostat will control the room temperature at the selected setting until you press the RUN button or switch thermostat off.

2) Temperature Override (When in the program RUN mode).

Press the ▲ or ▼ buttons to select the desired room temperature. The thermostat will override the current programming and keep the Room temperature at the selected temperature until the next program period begins. The thermostat will then revert back to the programmed temperatures.

3) Planning your program

Enter the Heating Program

1) Move the SYSTEM switch to the HEAT position.

2) Press PRGM once. PRGM SETTING will display, and "MON TUE WED THU FRI" (indicating weekday program) will appear in the display (flashing). Also displayed are the current programmed start time for the 1st heating period (flashing), and the currently programmed temperature.

3) Press the ▲ or ▼ buttons to select the desired 1st heating period start time. The time will change in 15 minute increments. When your selected time is displayed, press the TIME button to change to the temperature Set point mode.

4) Press the ▲ or ▼ buttons to select the desired 1st heating period temperature.

5) Press PRGM once. The currently programmed start time and set point for the 2nd heating program will appear.

6) Repeat steps 3 and 4 to select the start time and heating temperature for the 2nd heating program period.

7) Repeat steps 3 thru 5 for the 3rd and 4th heating program periods.

8) Press PRGM once. PRGM SETTING will display, and "SAT SUN" (indicating weekend program) will appear in the display (flashing). Also displayed are the current programmed start time for the 1st heating period (flashing), and the currently programmed temperature.

9) Repeat steps 3 thru 7 to complete Saturday and Sunday programming.

10) When you have completed entering your heating program, press **RUN**.

** NOTE: To set a scheduled program to OFF set your heat temperature to 7.0°C and your Cooling to 32.0°C

Enter the Cooling Program

- 1) Move the SYSTEM switch to the COOL position.
- 2) Follow "Enter the Heating Program" for entering your cooling program, using your selected cooling times and temperatures.

Note: The time of day clock MUST be set to the correct day and time in order for the programmed times to be correct. Look at the factory preprogrammed times and temperatures shown in the Factory default program setting. If this program will suit your needs, simply press the RUN button to begin running the factory preset program.

If you wish to change the preprogrammed time and temperature, follow these steps:

Determine the time periods and temperatures for your program. You must program four periods for each day. However, you may use the same heating and cooling temperatures for consecutive time periods. You can choose heating temperature, cooling temperature and start time independently. (for example, you may select 5:00 am AND 21°C as the weekday 1st period heating start time and temperature and also choose 7:00 AM and 24°C as the weekday 1st period cooling start time and temperature.

Use the table below to plan your program time periods and the temperatures you want during each period. Fill in the completed table to have a record of your program.

EXAMPLE:

Heating/Cooling Schedule Plan (Factory default program setting)

		Weekdays (5 day)		Saturday and Sunday	
Mode	Period	Start Time	Temperature	Start Time	Temperature
Heat	1 st	6:00 AM	21.0°C	6:00 AM	21.0°C
	2 nd	8:00 AM	16.5°C	8:00 AM	16.5°C
	3 rd	6:00 PM	21.0°C	6:00 PM	21.0°C
	4 th	10:00 PM	16.5°C	10:00 PM	16.5°C
COOL	1 st	6:00 AM	24.0°C	6:00 AM	24.0°C
	2 nd	8:00 AM	28.5°C	8:00 AM	28.5°C
	3 rd	6:00 PM	24.0°C	6:00 PM	24.0°C
	4 th	10:00 PM	25.5°C	10:00 PM	25.5°C

Heating/Cooling Schedule Plan

		Weekdays (5 day)		Saturday and Sunday	
Mode	Period	Start Time	Temperature	Start Time	Temperature
Heat	1 st				
	2 nd				
	3 rd				
	4 th				
COOL	1 st				
	2 nd				
	3 rd				
	4 th				

**** NOTE:** To set a scheduled program to OFF set your heat temperature to 7.0° C and your Cooling to 32.0° C

Check your programming

Follow these steps to check your thermostat programming one final time before beginning thermostat operation:

- 1) Move the SYSTEM switch to HEAT.

- 2) Press PRGM to view the 1st weekday heating period time and temperature.
 Each time you press PRGM the next heating period time and temperature will be displayed in sequence for weekday, then Saturday and Sunday program periods (you may change any time or temperature during this procedure).

- 3) Press RUN.

- 4) Move the SYSTEM switch to COOL.

- 5) Repeat step 2 to check the cooling program.

- 6) Move the SYSTEM switch to HEAT or COOL and press RUN to begin program operation.

REVERT TO FACTORY DEFAULT PROGRAM SETTINGS

Press the RESET button. All user's changed settings will revert to factory default settings (Including configuration settings).

1. Advanced Configuration Menu

The configuration menu allows you to set certain thermostat operating characteristics to your system or personal requirements. Move the SYSTEM switch to the OFF position, then press and hold the PRGM and RUN buttons for 3 seconds to enter the configuration menu. The display will show the first item in the configuration menu. Press the PRGM button to move to the next menu item, or press TIME to return to a previous menu item. To revert to factory default settings, press the RESET button (See Fig. 3). All user's changed settings will revert to factory default settings, including program settings. Use the ▲ or ▼ buttons to select.

To exit the configuration menu and return to normal operation, press the RUN button. If no buttons are pressed within 130 seconds, the thermostat will exit the configuration menu.

The configuration menu chart summarizes the configuration options. An explanation of each option follows.

Step	Press Buttons	Displayed (Factory Defaults)	Press ▲ or ▼ to select	Description
1	PRGM+RUN 5 seconds	CC (FA)	FA or SL	Select (FA)st or (SL)ow cooling cycles Default = FA
2	PRGM	HC (FA)	FA or SL	Select F(ast) or (S)low Heating cycles. Default = FA
3	PRGM	h0 (0)	0 or 1	Select system heating type, 0 = Gas, oil, or electric heating. 1 = Heat pump heating. Default = 0
4	PRGM	bL (2)	1 – 3	Select display backlight (1) = OFF, (2) = 30 seconds on any button push, (3) = ON. Default = 2. <u>Option (3) can be activated only if the common wire is used.</u>
5	PRGM	FL (00)	00, 1 thru12	Select filter time in months. Default = 00. A selection of “00” deactivates the filter feature.
6	PRGM	FC (C)	F or C	Select Temperature display to indicate °F or °C. Default = C
7	PRGM	CL (0)	+4 TO -4	Select temperature calibration point up to 4° higher or 4° lower. Default = 0
8	PRGM	CP (5)	0 or 5	Compressor Lockout delay. 0 = none 5 = 5 Minutes Default = 5
9	PRGM	IC	0 or 1	Intelligent Recovery Option. “1” = Active “0” = Deactivated. Default = 0
	RUN			Return to normal operation

1. Select cooling cycle rate

The FA setting is used to produce shorter cooling cycles. The SL setting produces a longer cooling cycle. Both settings produce very accurate temperature control and can be set to your personal preference. FA cycles the system at a 0.5°C differential, and SL cycles the system at 1.5°C.

2. Select heating cycle rate

The FA setting is used to produce shorter heating cycles. The SL setting produces a longer heating cycle. Both settings produce very accurate temperature control and can be set to your personal preference. FA cycles the system at a 0.5°C differential, and SL cycles the system at 1.5°C.

3. Select system heating type

Users can select the system heating type according to their heating system.
Select 0 for gas, oil, or electric heating systems. Select 1 for a heat pump heating system.

4. Select display backlight

The display backlight improves display contrast in low lighting conditions. Select 1 for NO backlight display. Select 2 for the backlight to come on for approximately 30 seconds when any button of the thermostat is touched. Select 3 for the backlight to remain on continuously.

NOTE: When operated from batteries (No "C" terminal connection), the LCD display backlight options are limited to option 1 (disabled) or option 2 (30 second illumination after each button press).

5. Select filter replacement run time

The thermostat will display the Filter Alarm after a set time of operation. This is a reminder to change or clean your air filter. This time can be set from 0 to 12 months in 1 month increments. Selection of 00 WILL CANCEL THIS FEATURE.

6. Select °F or °C readout

Changes the display readout to Centigrade or Fahrenheit as required.

7. Select temperature recalibration

This feature allows you to adjust the displayed room temperature up to 4° higher or lower. Your thermostat can be accurately calibrated to match your temperature measuring device. The current or adjusted room temperature will be displayed on the display.

8. Select compressor lockout delay

To protect the compressor from short cycling, you can select compressor off-time cycle between 0 or 5 minutes. When the thermostat compressor time delay occurs, the Cool On or Heat On display will flash during compressor lockout.

9. Intelligent recovery

When selected (1), The thermostat will calculate how long it takes to bring the room temperature up to the programmed set-point on the first set-up period of the day, and activate the system earlier so that the room temperature is at set-point at the set-up time.

Troubleshooting

If a voltage spike or static discharge blanks out the display or causes erratic operation, you can reset the thermostat by pressing the reset button (see figure 1). If the thermostat has power, has been reset and still does not function correctly, contact your heating/cooling service person or place of purchase.

Symptom	Possible Cause	Corrective Action
Heat, Cool or Fan Runs Constantly	1. Fan switch set to FAN ON 2. Possible short in wiring 3. Possible short in thermostat 4. Possible short in Heat/Cool/Fan system	Check each wire connection to verify they are not shorted or touching together. No bare wire should stick out from under terminal screws. Try resetting the thermostat as described below. If the condition persists, the manufacturer of your system or service person can instruct you on how to test the Heat/Cool system for correct operation. If the system operates correctly, replace the thermostat.

Furnace Cycles too fast or too slow	1. The location of the thermostat and/or the size of the heating system may be influencing the cycle rate.	Item 2 in the Configuration Menu is the adjustment that controls the heating cycle rate. If an acceptable cycle rate is not achieved using the FA or SL adjustment, contact a local service person for additional suggestions.
Cooling cycles too fast or too slow	1. The location of the thermostat and/or the size of the heating system may be influencing the cycle rate.	Item 1 in the Configuration Menu is the adjustment that controls the cooling cycle rate. If an acceptable cycle rate is not achieved using the FA or SL adjustment, contact a local service person for additional suggestions.
Thermostat Setting and Thermometer disagree	1. Thermostat thermometer setting requires adjustment.	The thermostat temperature calibration can be adjusted +/- 3 degrees as listed in item 7 of the Configuration menu. No other adjustment is possible.
Clock loses or gains time	1. Loss of power to thermostat and low batteries	The thermostat will maintain its program in memory even with no power and no batteries, but the clock time will be incorrect when power is restored. See No Heat/No Cool/No Fan above for items to check in the system.
Thermostat does not follow program	1. AM or PM set incorrectly in program 2. AM or PM set incorrectly on the clock 3. Voltage spike or static discharge	Check current clock and program setting including the AM or PM designation for each time period. If a voltage spike or static discharge occurs, use the Reset Operation listed above.
Blank display and/or keypad not responding	1. Loss of power and dead batteries. 2. Voltage spike or static discharge	Replace batteries and check heat/cool system for proper operation. If a voltage spike or static discharge occurs, use the Reset Operation listed above.

These instructions assume the installer of this thermostat has knowledge of Heating & Air conditioning systems, the terminology used in these systems and of the HVAC industry requirements.

It is an offence in Australia for unqualified persons to make any changes to Air-conditioning systems. Failure to observe this may void equipment and thermostat warranty, property insurance and cause irreparable damage to the thermostat or equipment connected to it.

Warranty 24 Months from date of purchase - RTB

For technical support please contact Smart Temp Australia P/L or an authorized sales / service agent.

Due to continual product improvement these specifications are subject to change without notice.

www.smarttemp.com.au www.thermostat.com.au